

Date: _____

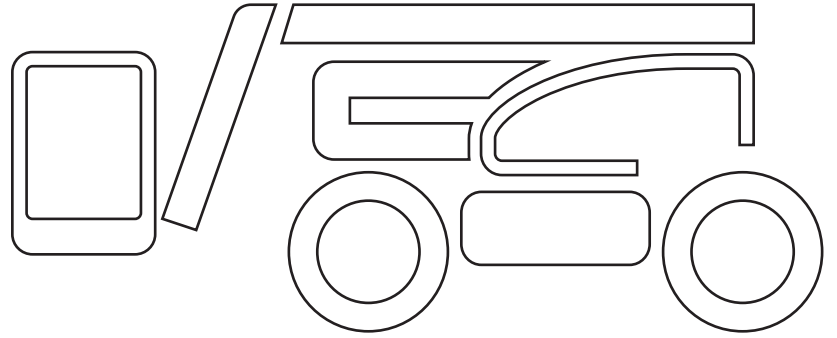

Colour me
nifty
Activity Book

Name: _____

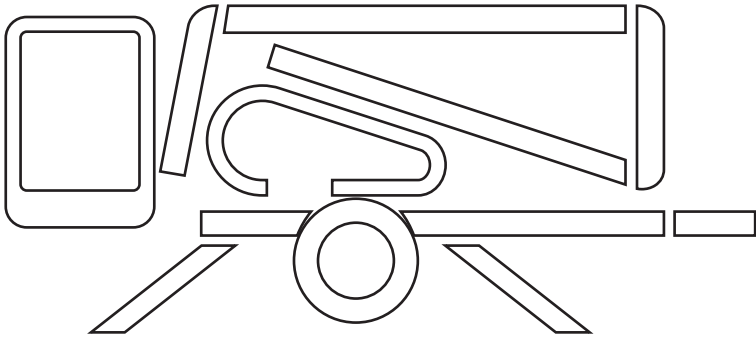
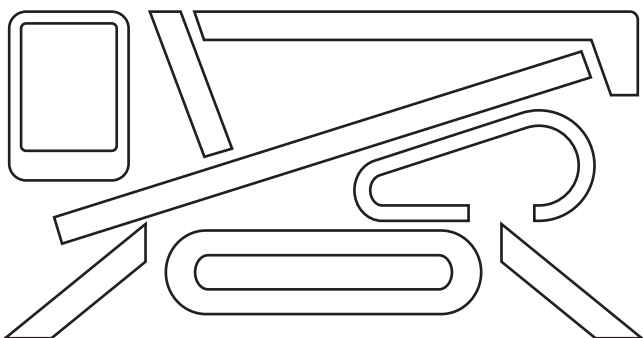
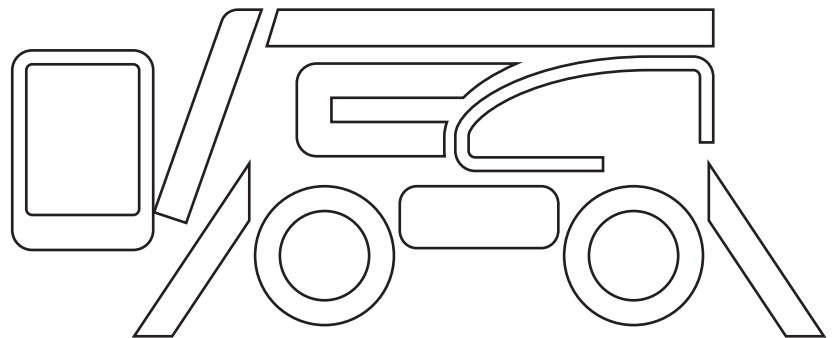

niftylift

Word Search

C	W	B	X	A	E	R	I	A	L	W	O	R	K	P	L	A	T	F	O	R	M	T	L	I
S	C	T	I	I	S	S	C	I	T	A	M	E	L	E	T	H	U	T	I	K	D	R	K	H
W	H	Y	R	G	V	L	T	L	P	T	J	Q	G	T	L	H	G	I	E	Y	N	A	I	A
O	E	E	W	H	T	X	F	G	B	Z	N	C	G	C	N	H	O	T	D	W	B	C	Q	M
R	R	V	V	O	I	C	I	C	C	O	H	I	A	O	L	D	L	P	B	G	C	K	K	M
K	R	I	X	E	K	Q	L	Q	D	I	N	T	F	M	X	O	D	L	D	H	B	D	N	M
I	Y	T	N	E	R	J	M	Z	B	L	L	Q	C	T	Q	X	F	H	Q	T	K	R	D	M
N	P	C	B	F	Y	F	O	O	I	B	K	U	M	K	Y	A	A	D	N	O	U	I	P	F
G	I	E	U	O	O	E	O	J	F	A	O	B	A	W	W	L	H	P	X	K	B	V	Z	V
H	C	F	Z	H	U	O	B	H	P	J	H	U	P	R	O	A	I	Q	B	N	K	E	Q	M
E	K	F	B	N	T	P	P	H	S	Z	B	X	T	E	D	S	M	F	U	U	P	A	Y	B
I	E	E	I	N	R	G	G	H	Q	A	L	H	P	R	U	Y	F	J	T	Z	J	L	Q	D
G	R	T	V	X	E	M	K	O	T	H	H	Q	L	D	I	X	H	W	N	U	Z	Z	S	Z
H	F	S	W	J	A	F	T	T	W	D	H	R	U	Y	U	G	O	E	I	A	D	Q	T	D
T	M	O	R	T	C	G	E	Y	Q	E	T	P	F	T	U	U	G	F	R	Z	E	P	G	Y
C	A	C	I	C	H	R	W	I	N	B	Y	O	R	W	K	E	G	E	W	F	I	L	P	L
O	O	D	N	O	Y	W	E	P	X	E	E	K	E	W	S	Q	C	D	R	O	X	X	L	P
F	E	T	J	Q	N	J	L	R	S	Z	V	J	W	N	X	U	O	Z	E	Y	E	U	K	L
O	L	P	T	B	T	O	S	Z	Z	J	Y	U	O	E	L	I	T	A	S	R	E	V	E	E
E	G	Q	G	L	N	L	L	A	J	D	F	I	P	A	X	T	N	L	L	T	H	V	L	E
T	F	X	P	J	Y	E	H	W	A	L	L	E	L	E	C	T	R	I	C	J	E	B	Y	A
J	E	F	T	N	R	M	R	O	F	T	A	L	P	K	R	O	W	S	G	Z	A	Z	N	C
M	O	I	E	T	S	R	Y	M	O	X	E	M	J	B	S	Q	B	P	G	R	E	E	Z	Z
G	I	Q	U	C	D	F	V	S	E	U	I	H	C	L	A	Q	F	N	U	I	J	V	H	T
N	A	S	V	Q	T	A	Q	R	T	V	J	C	N	H	K	C	N	D	T	Q	V	S	K	E
B	Y	G	Q	K	J	I	S	V	U	E	R	N	V	Q	L	J	U	C	M	A	M	X	A	Y
T	G	D	Z	P	T	Z	V	O	I	I	Y	T	O	K	F	H	A	A	P	X	V	U	P	L
C	J	W	T	F	K	R	E	E	Y	I	X	T	O	U	G	H	C	A	G	E	E	G	T	F

aerialworkplatform

allelectric

battery

boomlift

cherry picker

costeffective

durable

effective

hydraulic

nifty lift

outreach

outrigger

powerful

quiet

telematics

tough cage

track drive

versatile

working height

workplatform

LOCAL

HEROES

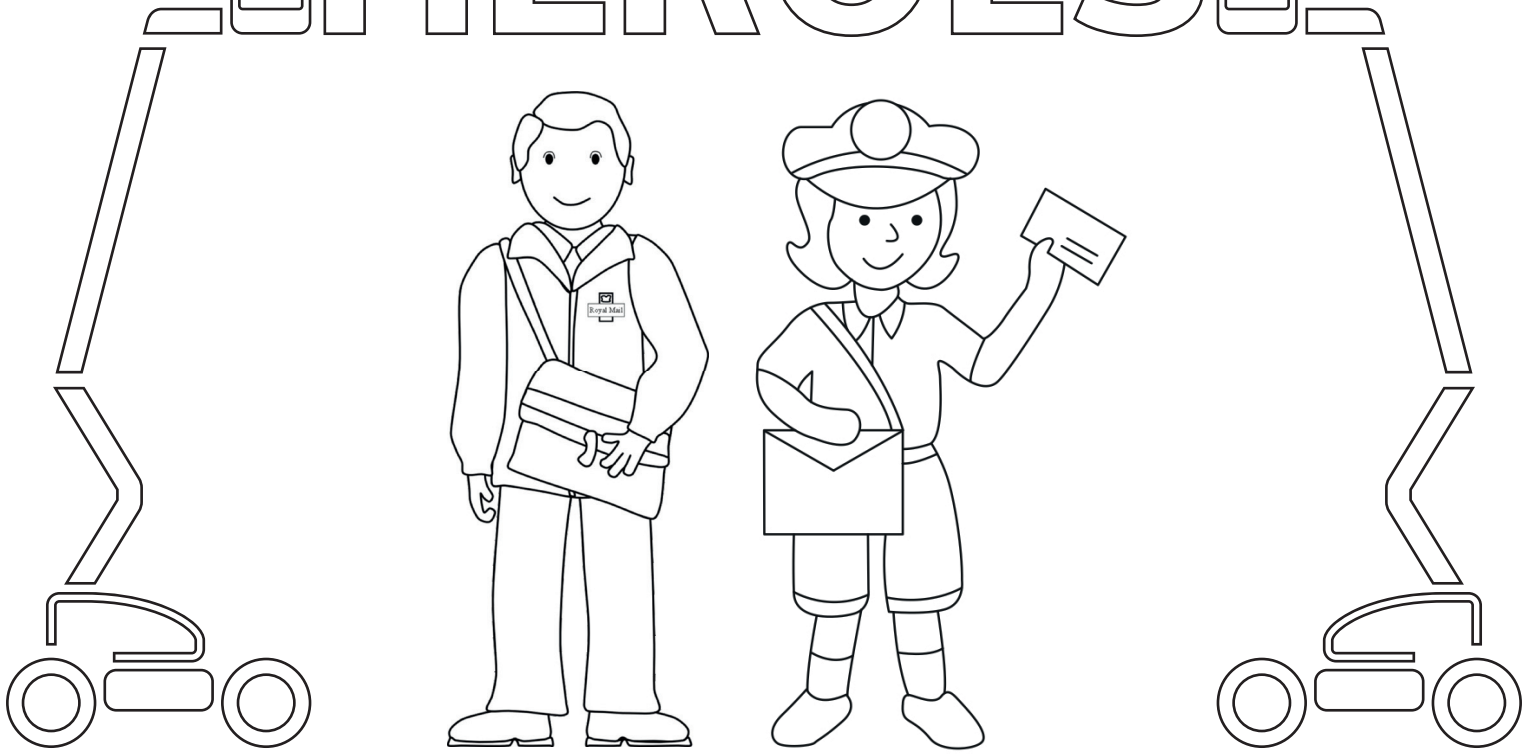

DELIVERIES

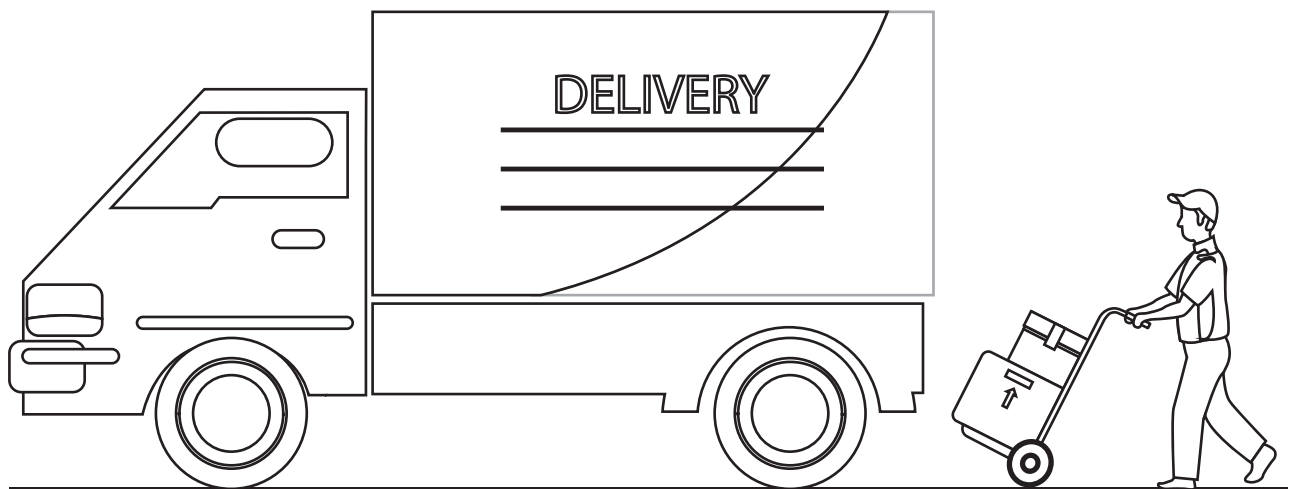

THANK YOU

Maze

START

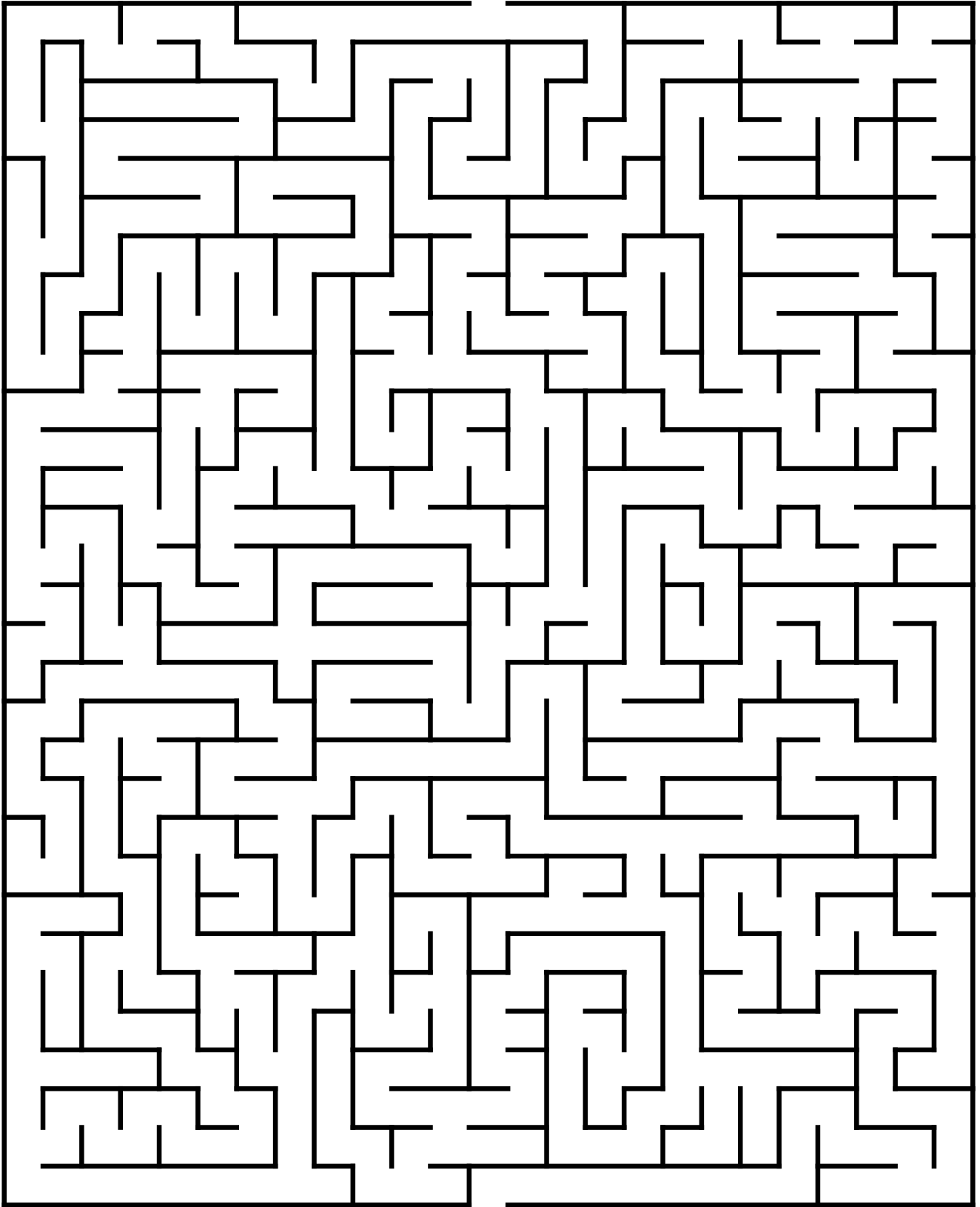

FINISH

Sudoku

Easy

8				6	4			
6			9					8
	4		2		5	1	3	
9	2	7						
		8				6		
						7	8	9
	7	6	3		2		9	
4					8			7
			6	7				4

Medium

	8	2		1	4			
7							4	8
				8		6		7
9	1	4					6	
			9		6			
	5					7	9	2
5		3		6				
2	6							3
			3	7		2	1	

Hard

2			3			8		
					8		9	3
					4	2	7	
8			2	4	7		1	
3								4
	1		8	5	3			2
	3	8	9					
6	2		7					
		1			2			8

Evil

		1	8	4				2
		8					9	
	6				3			
	8	2			7	3		9
9			1		2			4
6		5	9			7	2	
			3				4	
	5					2		
2				6	8	9		

LOCAL

HEROES

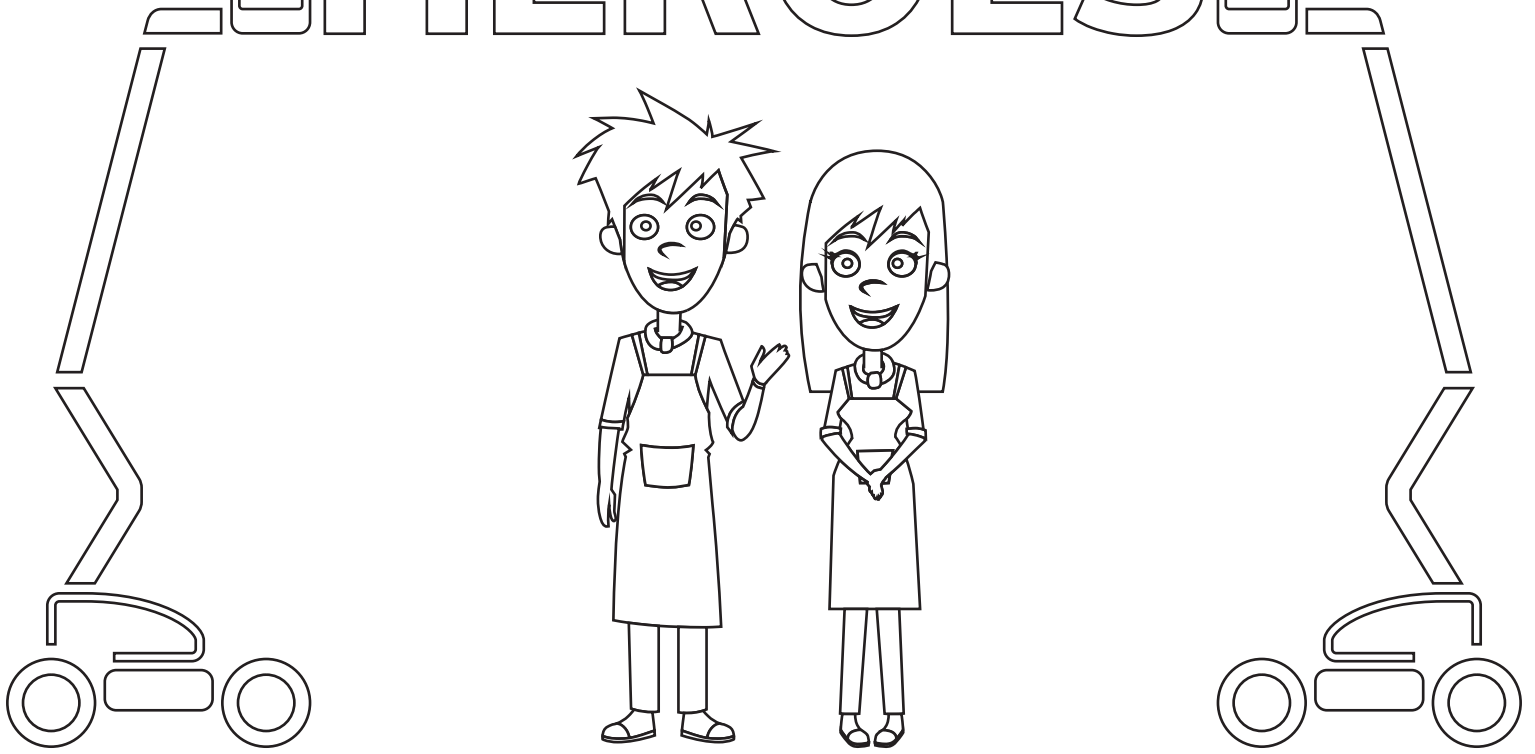

SHOP KEEPERS

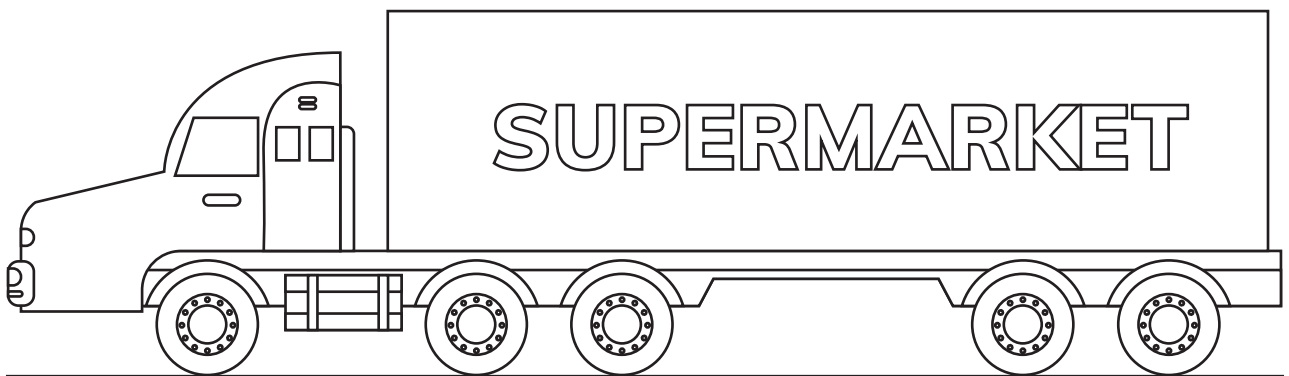

THANK YOU

Spot the Diff



Can you find all 10?



Answers

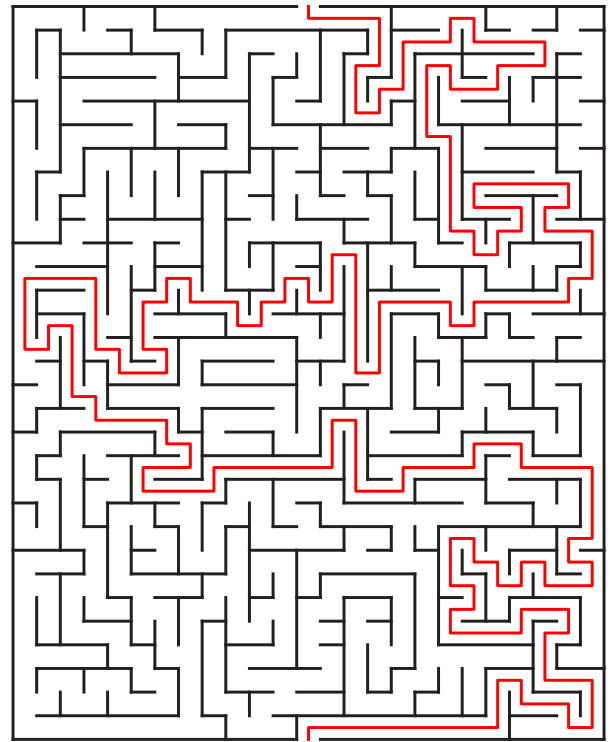
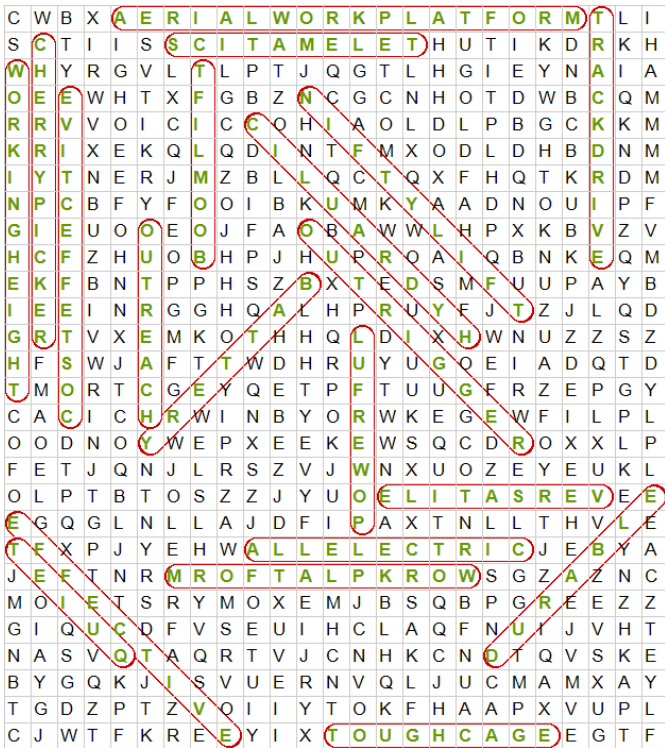

Easy

8	3	1	7	6	4	9	5	2
6	5	2	9	1	3	4	7	8
7	4	9	2	8	5	1	3	6
9	2	7	8	3	6	5	4	1
5	1	8	4	9	7	6	2	3
3	6	4	5	2	1	7	8	9
1	7	6	3	4	2	8	9	5
4	9	3	1	5	8	2	6	7
2	8	5	6	7	9	3	1	4

Medium

6	8	2	7	1	4	3	5	9
7	3	5	6	2	9	1	4	8
1	4	9	5	8	3	6	2	7
9	1	4	2	3	7	8	6	5
8	2	7	9	5	6	4	3	1
3	5	6	8	4	1	7	9	2
5	7	3	1	6	2	9	8	4
2	6	1	4	9	8	5	7	3
4	9	8	3	7	5	2	1	6

Hard

2	9	5	3	7	6	8	4	1
7	4	6	1	2	8	5	9	3
1	8	3	5	9	4	2	7	6
8	6	9	2	4	7	3	1	5
3	5	2	6	1	9	7	8	4
4	1	7	8	5	3	9	6	2
5	3	8	9	6	1	4	2	7
6	2	4	7	8	5	1	3	9
9	7	1	4	3	2	6	5	8

Evil

7	9	1	8	4	6	5	3	2
3	2	8	7	1	5	4	9	6
5	6	4	2	9	3	1	8	7
4	8	2	6	5	7	3	1	9
9	3	7	1	8	2	6	5	4
6	1	5	9	3	4	7	2	8
1	7	6	3	2	9	8	4	5
8	5	9	4	7	1	2	6	3
2	4	3	5	6	8	9	7	1



Please contact marketing@niftylift.com with any questions, comments or suggestions.